

## COMBI 1610/3 WH

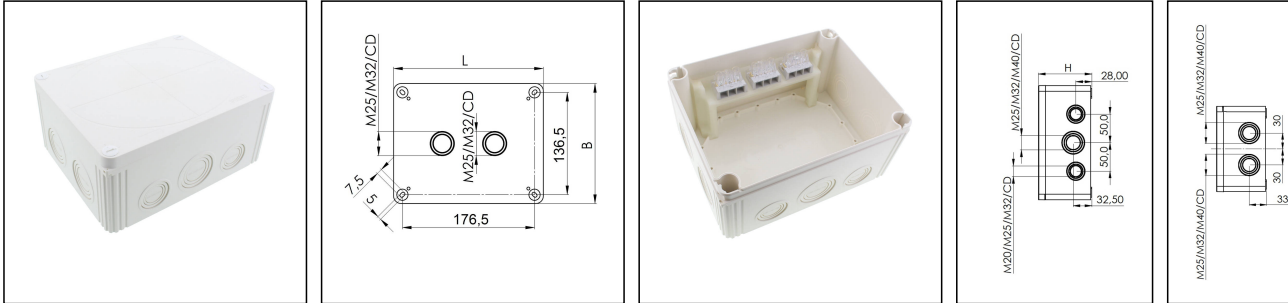

Products may differ in size, colour and appearance to those shown. If you require further information or customisation, please contact us directly.



<b>Material</b>	Polycarbonate
<b>Material sealing gasket</b>	PU
<b>Temp. range min</b>	-30 °C
<b>Temp. range max</b>	100 °C
<b>Temperatures during install.</b>	-5 °C - 60 °C
<b>Protection class</b>	IP66 / IP67
<b>Glow wire test</b>	960 °C
<b>Voltage</b>	690 V
<b>Rated cross section</b>	16 mm <sup>2</sup>
<b>Terminals/poles</b>	3-pole, 16,0 mm <sup>2</sup>
<b>External dimensions LxWxH</b>	200 x 160 x 94 mm
<b>Product Color</b>	RAL 9001
<b>Order no. RAL 9001</b>	10110744
<b>Type</b>	COMBI 1610/3 WH
<b>Packing unit</b>	1
<b>EAN number</b>	4007686251869
<b>Tariff number</b>	85369010
<b>ETIM-Classification</b>	EC002600

Remarks:

IP66: using the QUIXX self sealing membrane screw

IP67: using the knockout entry together with ESKV cable gland

Equipment:

- 10 knockouts side 6x M25/M32/M40; 4x M20/M25/M32

- 2 knockouts in the bottom 2x M25/M32

Your Contact:

**WISKA UK Ltd.**

Unit 7, Hurling Way · St. Columb Major Business Park · TR9 6SX, St. Columb Major, Cornwall · Great Britain

☎ +44-12-08816062 · 📠 +44-12-08816708

info@wiska.co.uk · www.wiska.co.uk

- 4 captive cover screws
- including 3 QUIXX membrane spout EMT 32
- CD (cable diameter) 6-28mm
- inclusive terminal block 3-poles, 16mm<sup>2</sup>

**Mounting:**

4 internal openings outside of the sealing area

**Recommended accessories**

External mounting - COMBI LG

10108836

**Spare parts**

SP-HKT 1610 Terminal block

22001224

04.06.2024

Your Contact:

**WISKA UK Ltd.**

Unit 7, Hurling Way · St. Columb Major Business Park · TR9 6SX, St. Columb Major, Cornwall · Great Britain

☎ +44-12-08816062 · 📠 +44-12-08816708

info@wiska.co.uk · www.wiska.co.uk

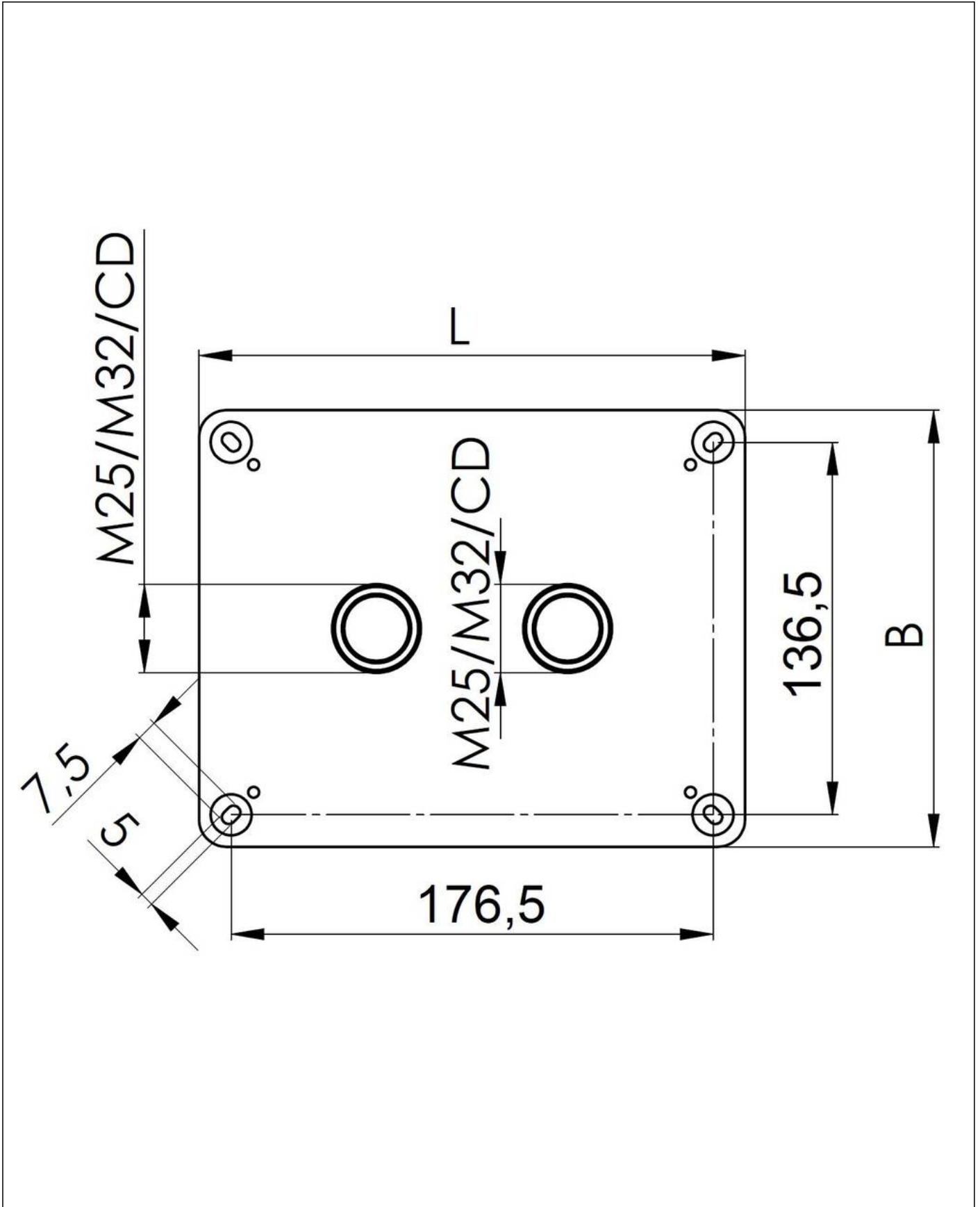

Your Contact:

**WISKA UK Ltd.**

Unit 7, Hurling Way · St. Columb Major Business Park · TR9 6SX, St. Columb Major, Cornwall · Great Britain

☎ +44-12-08816062 · 📠 +44-12-08816708

info@wiska.co.uk · www.wiska.co.uk

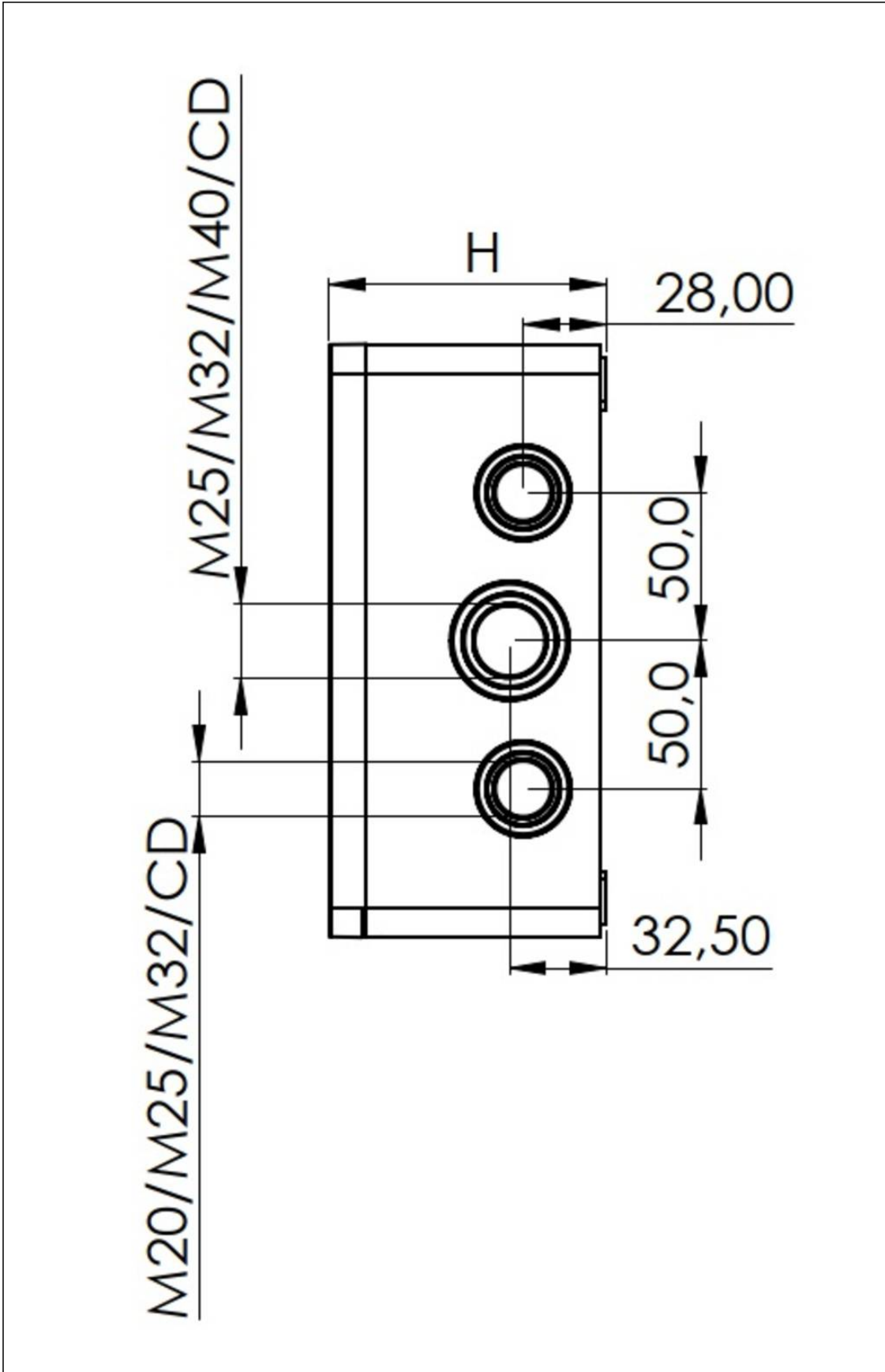

Your Contact:

**WISKA UK Ltd.**

Unit 7, Hurling Way · St. Columb Major Business Park · TR9 6SX, St. Columb Major, Cornwall · Great Britain

☎ +44-12-08816062 · 📠 +44-12-08816708

info@wiska.co.uk · www.wiska.co.uk